

PUNZÓN CABEZA CILÍNDRICA -MECHADO- ISO 8020. FORMA MEC.

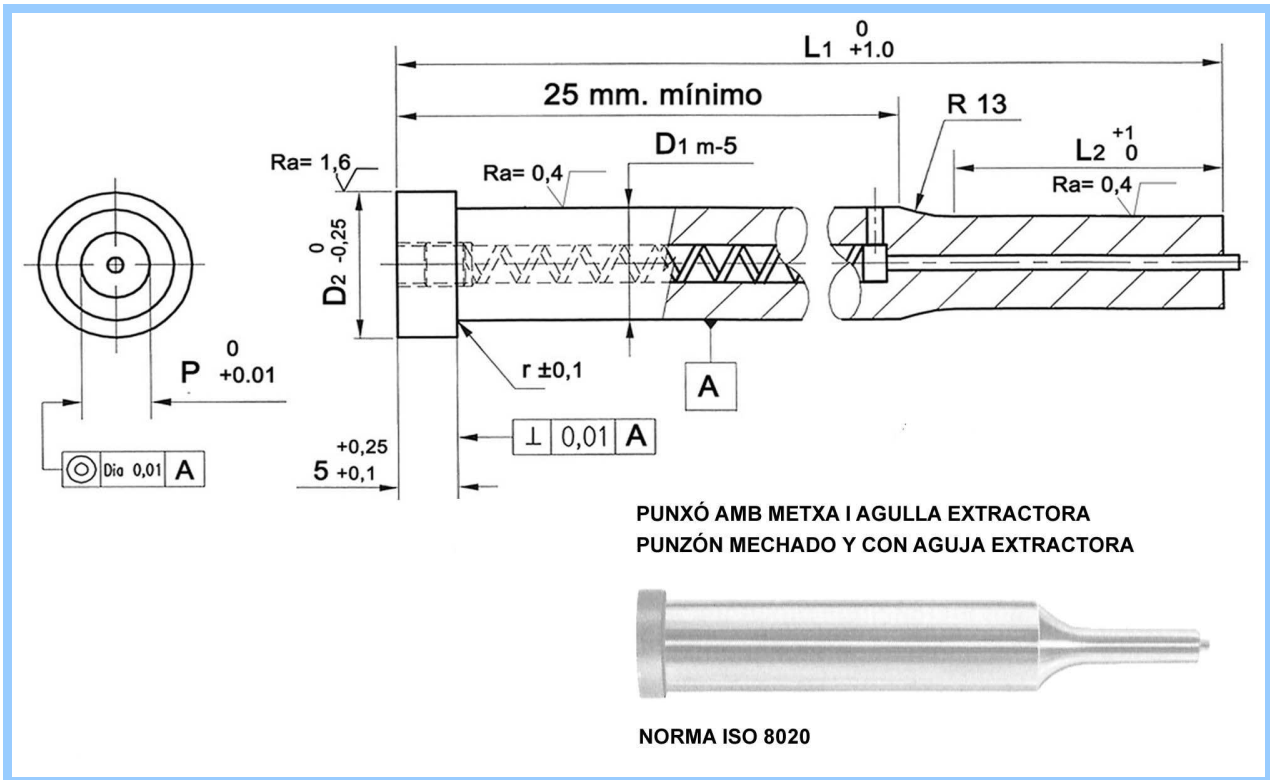

MATERIAL :

A-2 Acero 1.2363 (F-522)
M-2 Acero Súper Rápido HSS. 1.3343
SP Acero Pulvimetalúrgico – SINTERIZADO -

DUREZAS :

Vástago 60-63 HRc. Cabeza 40±5 HRc.
Vástago 60-63 HRc. Cabeza 50±5 HRc.
Vástago 63-65 HRc. Cabeza 50±5 HRc.

EJECUCIÓN. TEMPLADOS REVENIDOS Y RECTIFICADOS. CABEZA ESTAMPADA EN CALIENTE.

D ₁	P		D ₂	L ₂ +1				r	L ₁ +1								
	Mín.	Máx.		7	13	19	25		50	56	63	71	80	90	100		
5.0	2.00	4.99	8.0					0.25									
6.0	2.50	5.99	9.0														
8.0	3.00	7.99	11.0														
10.0	4.00	9.99	13.0														
13.0	5.00	12.99	16.0					0.40									
16.0	8.00	15.99	19.0														
20.0	12.00	19.99	23.0														
25.0	16.50	24.99	28.0														
32.0	20.00	31.99	35.0														

FABRICACIÓN HABITUAL, CONSULTAR PLAZO, OTRAS MEDIDAS. BAJO DEMANDA.

TRATAMIENTOS SUPERFICIALES TIN, TIN-C, ETC., ACONSEJABLE SOBRE PUNZONES CALIDAD M-2 Y SP.

Escalonado diámetro P → 0.01 mm.

EJEMPLO PDO.: D₁ – L₁ – P – L₂ – Calidad – Posicionado (ver pág. 1.1.15)

