

CASQUILLO CORTE DIN-9845 LISO FORMA A CON VALONA FORMA B

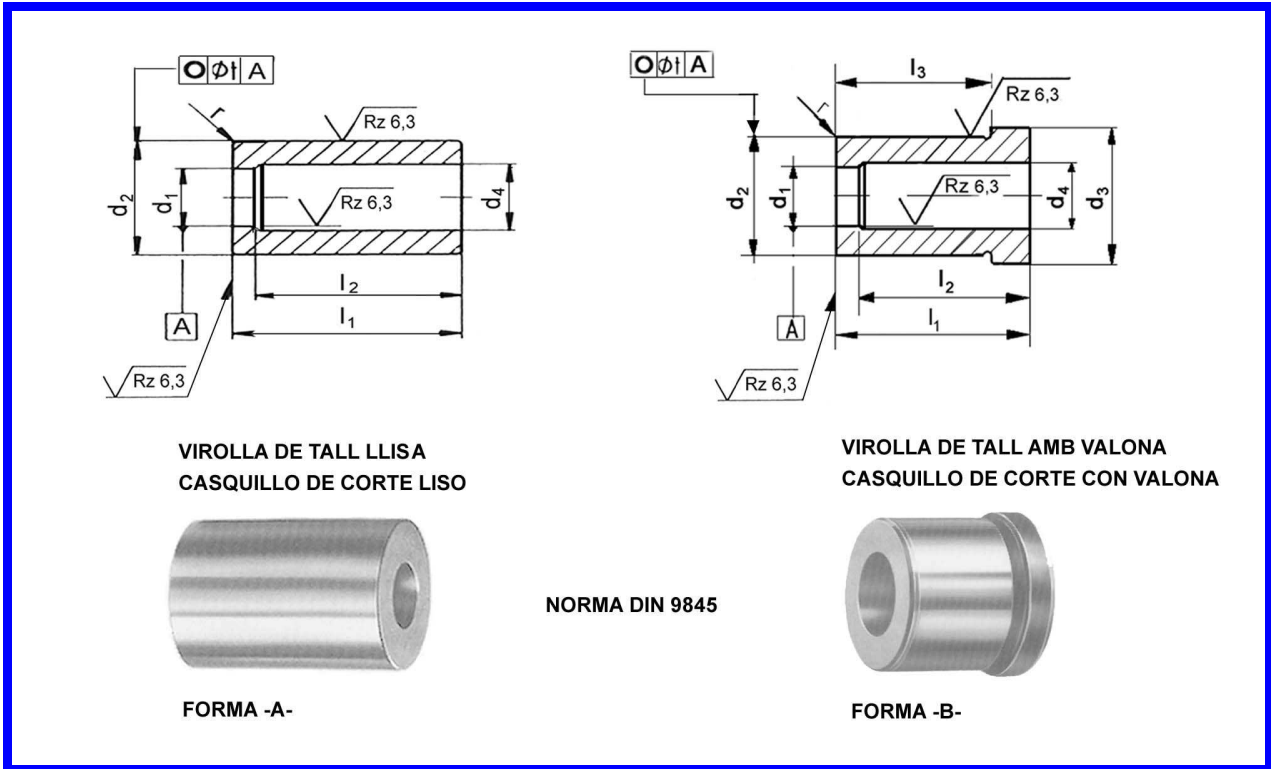

MATERIAL:

- HWS - Acero al 12% CROMO 1.2080
- WS - Acero F-522
- HSS - Acero rápido 1.3343

DUREZAS:

- 60-62 HRc.
- 60-62 HRc.
- 62-64 HRc.

EJECUCIÓN: TEMPLADOS Y RECTIFICADOS, DIÁMETRO INTERIOR H-8
 DIÁMETRO EXTERIOR n-6 para tipo-A- y k-6 para tipo-B-

| d ₁ H-8 | Escalonado en mm. | d ₂ Tipo-A : n-6 Tipo-B : k-6 | d ₃ | d ₄ ±0,1 | Cortos | | | Largos | | | r | t |
|--------------------|-------------------|--|----------------|------------------------|---------------------|----------------|----------------|---------------------|----------------|----------------|-----|------|
| | | | | | l ₁ +0,5 | l ₂ | l ₃ | l ₁ +0,5 | l ₂ | l ₃ | | |
| 1.0 | 0.10 | 5.00 | 7.00 | d ₁ +0.3 | 20.0 | 18.0 | 16.0 | --- | --- | --- | 0.3 | 0.01 |
| 1.10 a 2.0 | | 6.00 | 8.00 | d ₁ +0.3 | 20.0 | 17.0 | 16.0 | 28 | 25.0 | 24.0 | 0.3 | |
| 2.10 a 3.0 | | 7.00 | 9.00 | d ₁ +0.5 | 20.0 | 17.0 | 16.0 | 28 | 25.0 | 24.0 | 0.4 | |
| 3.10 a 4.0 | | 8.00 | 10.00 | d ₁ +0.5 | 20.0 | 17.0 | 16.0 | 28 | 25.0 | 24.0 | 0.4 | |
| 4.10 a 5.0 | | 10.00 | 12.00 | d ₁ +0.7 | 20.0 | 16.0 | 16.0 | 28 | 24.0 | 24.0 | 0.4 | |
| 5.10 a 6.0 | | 12.00 | 14.00 | d ₁ +0.7 | 20.0 | 16.0 | 16.0 | 28 | 24.0 | 24.0 | 0.6 | |
| 6.10 a 8.0 | | 15.00 | 17.00 | d ₁ +0.7 | 20.0 | 16.0 | 16.0 | 28 | 24.0 | 24.0 | 0.8 | |
| 8.10 a 10.0 | | 18.00 | 20.00 | d ₁ +1.0 | 20.0 | 16.0 | 16.0 | 28 | 24.0 | 24.0 | 0.8 | |
| 10.10 a 12.0 | | 22.00 | 24.00 | d ₁ +1.0 | 20.0 | 15.0 | 16.0 | 28 | 23.0 | 24.0 | 0.8 | |
| 12.10 a 15.0 | | 26.00 | 28.00 | d ₁ +1.0 | 20.0 | 15.0 | 16.0 | 28 | 23.0 | 24.0 | 0.8 | |
| 15.50 a 18.0 | 0.50 | 30.00 | 32.00 | d ₁ +1.0 | ---- | ---- | ---- | 28 | 23.0 | 24.0 | 1.0 | 0.02 |

BAJO DEMANDA OTROS DIÁMETROS.

