

CASQUILLO GUÍA PUNZÓN – GUIP – DIN. 9845 – C.

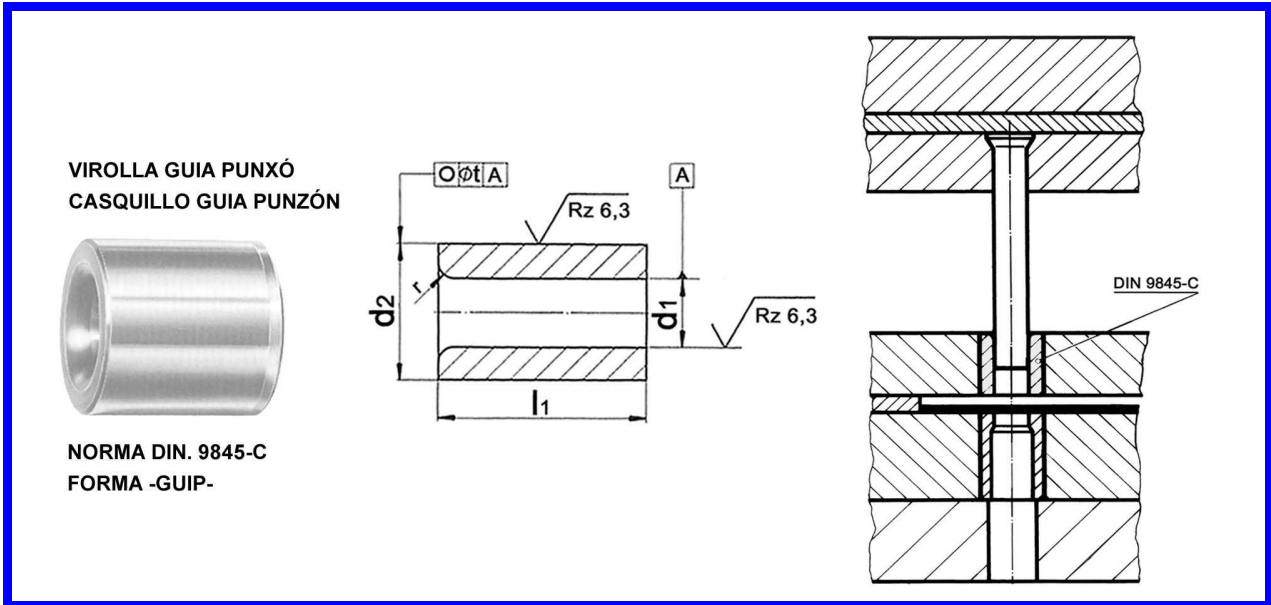

MATERIAL:

WS Acero F-522 (1.2510)

DUREZA:

60-62 HRc.

EJECUCIÓN: TEMPLADOS, REVENIDOS Y RECTIFICADOS.

d_1 -H7	d_2	l_1	r	t
1.0	5.0	9.0	1.0	0.02
1.1 a 2.0	6.0	12.0		
2.1 a 3.0	7.0	12.0		
3.1 a 4.0	8.0	12.0		
4.1 a 5.0	10.0	16.0	1.5	0.05
5.1 a 6.0	12.0	16.0		
6.1 a 8.0	15.0	20.0	2.0	
8.1 a 10.0	18.0	20.0		
10.1 a 12.0	22.0	28.0		
12.1 a 15.0	26.0	28.0		
15.5 a 18.0	30.0	36.0		

Escalonado diámetro d_1 : de 1.0 a 15.0 → 0.10 mm.
de 15.5 a 18.0 → 0.50 mm.

BAJO DEMANDA OTROS DIÁMETROS Y LONGITUDES